

## LENNOX' ELITE® SERIES

Home Comfort Systems

**CBX27UH/CB27UH**

High-static air handler



**LENNOX**

HOME COMFORT SYSTEMS  
*Innovation never felt so good.™*



# Elite® Series CBX27UH/CB27UH Air Handler

Innovation never felt so good.™

Enhanced air performance—  
5 ton delivers 2000 CFM at  
.8 ext. static pressure

Up-flow/horizontal  
configurations allow  
maximum flexibility  
in installation

Model CBX27UH equipped  
for non-ozone-depleting  
R410A refrigerant. Model  
CB27UH equipped for  
R22 refrigerant.

Meets Florida standards for  
less than 2% air leakage  
from unit

### WARRANTY\*

5-year limited warranty  
on the coil and all  
covered components.

\*Applies to residential applications only.  
See actual warranty certificate for details.

### Quality you can trust.

*Every copper distributor tube that carries refrigerant from the thermal expansion device to the coil is sleeved with a polyethylene tube to prevent leaks and provide long-lasting, worry-free performance.*

## ECONOMICAL, HIGH-EFFICIENCY COOLING AND HEATING

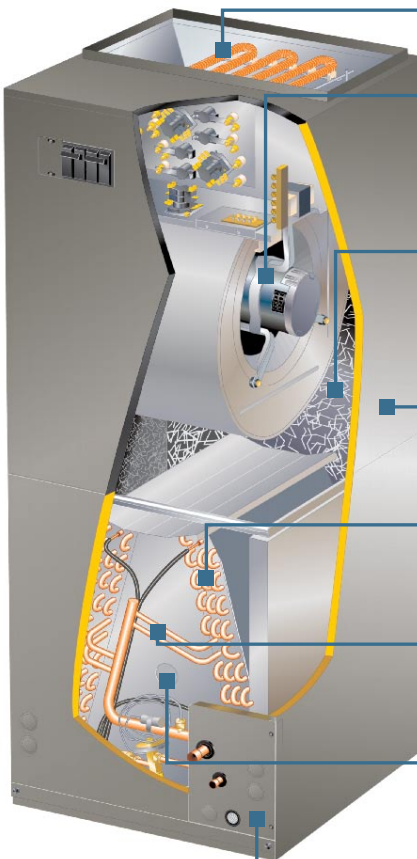

**Optional Electric Heat** – Provides supplemental heat for added comfort.

**High-Efficiency, Direct-Drive Blower Motor** – Delivers high cooling and heating efficiencies for improved performance.

**Fully Insulated Cabinet** – Reduces sound for quiet operation. Foil face insulation for improved mold reduction and indoor air quality.

**Durable Steel Cabinet** – Made to last with an attractive, high-quality textured-paint finish.

**High-Efficiency Evaporator Coil** – Provides exceptional heat transfer and efficiency.

**Efficient Check and Expansion Device** – Ensures efficiency across a wide range of operational conditions.

**Pre-punched UV Knockout** – Makes adding a Healthy Climate® Germicidal Light to your air handler quick and easy, improving indoor air quality by helping eliminate household contaminants such as mold and bacteria.

**Antimicrobial Drain Pan** – Includes an antimicrobial agent that inhibits mold and mildew growth and is made of a durable composite material that won't corrode or rust.



### Elite® Series CBX27UH/CB27UH Specifications

CBX27UH/CB27UH	018	024	030	036
Dimensions HxWxD (in.)	49-1/4 x 21-1/4 x 20-5/8	49-1/4 x 21-1/4 x 20-5/8	51 x 21-1/4 x 22-5/8	51 x 21-1/4 x 22-5/8
HxWxD (mm)	1251 x 540 x 524	1251 x 540 x 524	1295 x 540 x 575	1295 x 540 x 575
CBX27UH/CB27UH	042	048	060	
Dimensions HxWxD (in.)	58-1/2 x 21-1/4 x 24-5/8	58-1/2 x 21-1/4 x 24-5/8	62-1/2 x 21-1/4 x 24-5/8	
HxWxD (mm)	1486 x 540 x 625	1486 x 540 x 625	1588 x 540 x 625	

Note: Due to Lennox' ongoing commitment to quality, all specifications, ratings and dimensions are subject to change without notice.



HOME COMFORT SYSTEMS  
Innovation never felt so good.™

(95M76) CB27UH 04/08  
PC53620

© Lennox Industries Inc. 2005

Visit us at [www.lennox.com](http://www.lennox.com), or contact us at 1-800-9-LENNOX.